

SCHMEISER LAND LEVELER

ASSEMBLY & PARTS MANUAL

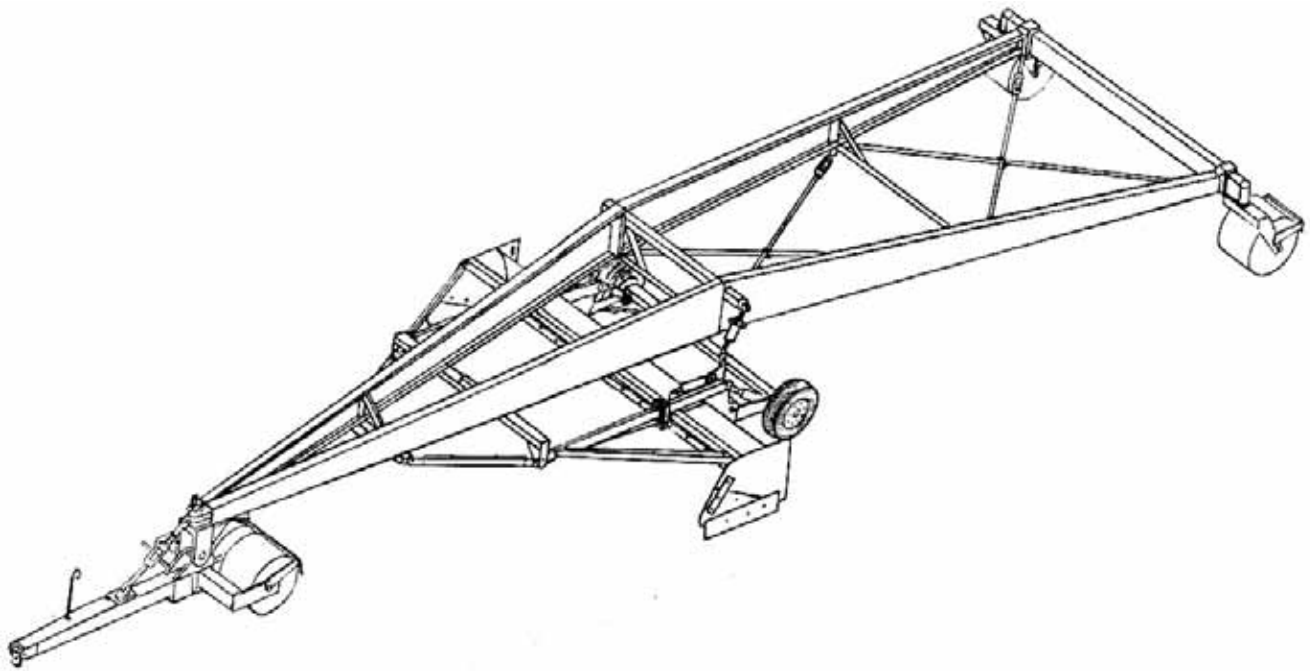

T. G. SCHMEISER CO., INC.

P.O. BOX 1047 FRESNO, CA 93714-1047
(559) 268-8128 FAX (559) 268-3279
www.tgschmeiser.com

VERSION 1.4

Blank Page

INTRODUCTION

Your Schmeiser Land Leveler is designed to give you many years of dependable service. This manual has been prepared to instruct you in the safe and efficient operation of this machine. Read and study it thoroughly. Follow all instructions carefully.

Should your Land Leveler require replacement parts, go to your Schmeiser dealer. Always order genuine Schmeiser replacement parts.

It is important you complete and send in your Warranty Card because it is not valid unless it is on file at Schmeiser. If you need information not contained in this manual, contact your Schmeiser dealer.

Space has been provided below for you to record your model number and serial number of your leveler. Be sure to bring this information with you to your dealer when ordering parts or attachments for your leveler.

Thank you for buying a Schmeiser Land Leveler.

Serial Number_____

Model Number_____

Date Purchased_____

Dealer Name_____

Blank Page

TABLE OF CONTENTS

Introduction.....	A
Table of Contents.....	B
Set Up Instructions.....	1
Land Leveler Road Transport.....	6
Land Leveling.....	6
Hydraulic Cylinder Option.....	7
Complete Assembly.....	9
Bucket Assembly.....	11
Bucket Bolt-Up Assembly.....	13
Bucket Linkage Assembly.....	15
Tongue Assembly.....	17
Main Frame Pivot Shaft Assembly.....	19
Turnbuckle Assembly.....	21
Front Steel Wheel Assembly.....	23
Rear Steel Wheel Assembly.....	25
Tire Axle Assembly.....	27
Tire Axle Hydraulic System Assembly.....	29
Hydraulic Bucket Lift System Assembly.....	31
Quad Tire Assembly.....	33
Warranty.....	35

Blank Page

LAND LEVELER 40 SET UP INSTRUCTIONS

THE FOLLOWING TOOLS ARE NEEDED:

1. Truck with lifting boom, overhead hoist or forklift with 2000 pound lifting capacity.
2. A 24" adjustable wrench or large pipe wrench.
3. One 6" and two 12" adjustable wrenches.
4. Socket wrench with 15/16" and 1-1/2" sockets.
5. Heavy duty pliers.
6. A heavy duty 12" screwdriver.
7. A 14" tapered drift punch.
8. A pry bar.
9. A medium size ballpeen hammer.
10. A ten pound sledge hammer.
11. Grease gun.

PROCEDURE:

1. Select a smooth level piece of ground approximately 60' x 100' to assemble the SCHMEISER landleveler. Place the bucket, with the bucket cross brace attached, in the center of the level piece of ground and facing the direction in which the machine is to be pulled. Place a wooden block (2" x 6" or 2" x 8" approximately 24" long) under each bucket side plate to prevent sinking and place at least one or preferably two column supports under the bucket cross member to hold it in position for bolting to the main frame.
2. Place the rear cross frame approximately 20 feet in back of the bucket and turn the wheels so they are parallel to the cross frame; then the unit will stand without additional support.
3. Place the right front and rear main frames on the right side of the bucket (standing behind the bucket looking forward) flat and on two pieces of wood (2" x 6" or 2" x 8" approximately 36" long) under each main frame, one near each end. Place the main frame with the front bearing clamp welded on toward the front and with the

butt or large end about even with the bucket roll. Place the right rear main frame butt to butt with the right front main frame. Slide together. Line up the mating holes and install (2) 1-1/4" NC x 4-1/2" Gr.8 bolts with lock washers and hex nuts and (1) 5/8" NC x 2" bolt with lock washer and hex nut in the hole near the bottom 1-1/4" NC bolt. Tighten all three.

4. Attach chain or sling to the bolted right main frames. Hoist the main frames up and position them over the bucket and bucket cross brace right end. Line up the mating holes of the bucket cross brace and the main frame mounting plate. Install four 5/8" NC x 4-1/2" bolts, lock washers and hex nuts; snug up with wrench but do not tighten. Place one assembly stand under the bucket cross brace as close to the attached main frame as possible and one assembly stand under the back end of the main frame just high enough that the rear cross frame can be attached.
5. Position the rear cross frame against the flat plate on the rear end of the main frame. Adjust the main frame height (if necessary) so that the two 8" U-bolts can be placed around the rear cross frame tube and inserted through the four mating holes in the end plate of the rear main frame. Insert four 7/8" NF hex nuts and lock washers. Snug up but do not tighten. It must be loose enough to move for sideways adjustment.
6. Hoist the center cross frame up with sling or chain attached to the 3" x 3" tube so that the cross frame is parallel to the ground and oriented to the square hole in the upper middle section of the right main frame. Make sure the cross frame is positioned so that the attaching bracket on the bottom side of the 3" x 3" square tube is flush on the side facing the forward end of the machine. Now slide the end of the square tube through the square hole in the frame until the two attaching holes match up. Install one 1" x 3-1/2" bolt with lock washer and hex nut and one 5/8" x 2" bolt with lock washer and hex nuts. Tighten securely. Place an assembly stand under the center cross frame base angle to support it in a level position.
7. Place the left front and rear main frames on the left side of the bucket and repeat the assembly procedure of Step 3 to assemble the left main frames.
8. Attach a chain or sling to the bolted left main frames. Hoist them up, line the square hole in the frame up with the 3" x 3" square tube of the center cross frame. Slide the frame onto the tube until the 1" NC x 3-1/2" bolt can be installed through the tube and the hole in the butt plate. Install the lock washer and hex nut. Snug up

- only, do not tighten.
9. Align the main frame over the bucket cross brace matching the holes. Install four 5/8" NC x 4-1/2" bolts, lock washers and hex nuts. Snug up. Do not tighten.
 10. Install the other two 5/8" NC x 2" bolts in the center cross frame/main frame holes. Do not tighten.
 11. Swing the rear cross frame into position against the left main frame rear attaching plate, adjust to install two 8" U-bolts and four 7/8" NF hex nuts and lock washers. Snug up. Do not tighten. Both 8" U-bolts must be loose enough to slide on the rear cross member for final adjustment.
 12. Install the front steel wheel frame and main frame pivot shaft assembly (with bearing housing, thrust bearing, inner races, pin bearings, shaft cap, oil seal & dust cap) into the bearing clamp recess on the front end of the right and left main frames. Squeeze the bearing clamps together and line up the six mating holes. Install six 3/4" NC x 2" bolts, lock washers and hex nuts. Tighten up enough to hold head tube in place and place lock pin in position.
 13. Hoist the tongue with wheel(s) attached into position at the front of the machine. Line up and position the extended rear section of the tongue with the main frame pivot shaft assembly mounted between the bearing clamps. Line up the mating holes and install the main pivot shaft clevis pin, castle nut and cotter pin.
 14. Install turnbuckle assembly. Connect one end to the top hole in the bearing clamp and the other clevis end to the tongue turnbuckle anchor. Use two clevis pins 1" x 2-1/2" and two 1/4" x 1-3/4" lynch pins. Adjust tongue to be parallel with the ground by adjusting the turnbuckle.
 15. Install rear inside frame. Use four 5/8" NC x 2" bolts, lock washers and hex nuts. Snug up only to allow slight movement.
 16. Install front locking plate (with two slotted holes). Use two 3/4" NC x 3" bolts, flat washers, lock washers and hex nuts. Snug up only.
 17. Install front cross frame between the front locking plate and main frame. Use three 3/4" NC x 2" bolts, lock washers and hex nuts and two 5/8" NC x 2" bolts with lock washers and hex nuts. Snug up only.
 18. Install right and left pull braces (the left one has two pins welded to it to mount the front turnbuckle when

leveler is in field position) using four 3/4" NC x 2" bolts, lock washers and hex nuts. Attach between the front cross brace and the bucket cross brace. Snug up only.

19. Push the tire axle under the main frame. Align the tire axle so that when mounted to the rear of the bucket, the cylinder anchors are on the backside toward the rear cross frame. Now push the tire axle up until the legs slide into the gussets on the rear of the bucket. Line up the holes and insert a 1" NC x 3-1/2" bolt with zerks, through each hole. Put a locknut on each bolt and tighten.
20. Install two short cross rods (crossed) between the center cross frame and the rear inside frame. Use two 5/8" NC x 2" bolts, lock washers and hex nuts at center cross frame and two 5/8" NC x 2" bolts, lock washers and hex nuts at the rear inside frame end. Leave the rod assemblies loose.
21. Now install the two long cross rods (crossed) between the rear inside frame and the rear cross frame. Use two 5/8" NC x 2" bolts, lock washers and hex nuts at the rear cross frame end and two 5/8" NC x 2" bolts, lock washers and hex nuts at the rear inside frame end. Leave the rod assemblies loose.
22. Adjust the right and left main frame spacing on the rear cross frame. It should be centered by measuring from head tube to edge of main frame plate and sighting along the outside edge of both main frames to make sure they are not bowed in or out. Then tighten all eight 7/8" NF nuts onto the 8" U-bolts securely.
23. Tighten up all eight cross rod attaching bolts.
24. Tighten up all four cross rod turnbuckles sufficiently to square up the frames. Then install the cross rod U-bolts.
25. Tighten all bolts in front cross frame, bucket cross brace and rear inside frame.
26. Install T-bar lift arms on bucket top rear section with cylinder attaching extension pointing toward the front of the machine and the short end (distance from end hole to cylinder attaching hole) mounted on the bucket. Use one 1" NC x 6" bolt with nylon lock nut.
27. Install lift link turnbuckle assembly onto the end of the center cross frame. Align the turnbuckle so that the locking handle is located at the top; now slide the tube over the stub. Install end plate and 1/2" NC x 1-1/2"

bolt with lock washer. To attach the bottom end of the lift link assembly, line up the lift link clevis end with the T-bar link end hole. Adjust the turnbuckle by turning, clockwise or counterclockwise until the mating holes line up and the 1" NC x 3-1/2" bolt can be installed; then install 1" nylon lock nut. Make sure the grease fitting is facing out for ease of lubricating.

28. To install the other lift link, follow the same procedure as indicated in Step 27.
29. Install two 3-1/2" x 8" cylinders onto the tire axle. Use 1" x 4" cylinder pins. Position the shaft end clevis straddle of the cylinder attaching lug. Insert the cylinder pin and secure with hitch pin clips. Position the other clevis end straddle of the bucket attaching lug. Insert the cylinder pin and secure with hitch pin clips.
30. Install hydraulic piping and fittings from the front of the machine to the tire axle and install the 33" hoses into the upper port of the cylinders and the lower set of cross pipes. Use teflon tape for thread sealant on all pipe and hose joints. Support the piping with five double pipe clamps; one on the angle welded on the top front of the main frame, one on the front cross brace, one on each pipe hanger located on center cross frame base angle pointing toward the ground. Use five 5/16" NC x 2-1/2" bolts, lock washers and hex nuts.
31. Install one straight link lock between the T-bar and cylinder adjusting screw, which is mounted on the bucket hanger tube (one on each side of the machine) using two 1" NC x 3" bolts, lock washer and hex nuts mounted to the adjusting screw and two 1" NC x 3" bolts with nylon lock nuts mounted to the T-bar link.
32. Make a final check of the assembled landleveler. Cross rods should be tightened. The jam nut should be locked up against the turnbuckle. The front turnbuckle must be adjusted correctly. Lock pins should be in place. Make sure all frame and cross member bolts are tight. 8"-U-bolts must be tight and positioned correctly on the rear cross frame.
33. Optional bucket hydraulics with the transport hydraulics. Install pipes and fittings from the front of the machine to the center cross frame base angle; also the cross pipes. Use five double pipe clamps; one on the front main frame opposite the transport pipe hanger with 5/16" x 2-1/2" bolts, lock washers and hex nuts, two piggyback on top of the transport pipe clamps with 5/16" x 5" bolts, lock washers & hex nuts, and two on each pipe hanger located on the center cross frame opposite the

transport cross lines with 5/16" x 2-1/2" bolts, lock washers and hex nuts.

TO TRANSPORT THE LANDEVELER ON THE ROAD:

1. Move the bucket to its lowest position, then install the cylinder locking bars. The tire axle will be up and lock pins in place. Remove both lock pins from the tire axle. Lower the tire axle hydraulically until the lock pins can be reinserted into the same holes. This will lock the wheels into the transport position with the rear steel wheels off the ground.
2. Align the tongue with the frame center line, then insert the pivot shaft lockout pin, with the wrench portion up, between the frames and through the rear hole of the front main frame pivot shaft.
3. Adjust the front turnbuckle to hookup to the tractor drawbar, then readjust for the wheel/ground clearance desired.
4. Do not try to move the landleveler on the road on its steel wheels. Always use the transport wheels when moving on roadways.

TO LOWER LANDEVELER FOR LAND LEVELING:

1. Lower the tire axle hydraulically enough to remove the locking pins. Raise the tire axle slowly until the front or rear wheels touch the ground. Adjust the front turnbuckle until the pins are free. Remove the turnbuckle and mount it on the left pull brace with two lynch pins.
2. If the machine does not have a hydraulically actuated bucket, lift arm locks must be used on each side.
3. Remove the pivot shaft lockout pin, the 1" shaft between the front ends of the frame, place it in the pin holder bracket at the front of the machine.
4. The bucket leveling and depth adjustments are made by adjusting the lift screws located on each side of the landleveler.
5. Check the rear wheels for travel alignment:
 - a. Loosen both stabilizer bearing cap screws to assure that the bearing or roller is free to move in the slot.

- b. Stretch a string from the outside of one wheel rim to the outside of the opposite wheel rim approximately 14" off of and parallel to the ground.
 - c. Adjust each wheel so that the string touches the full surface of each wheel rim with no bend in the string. (Visually check from outside of one wheel to the outside of the other)
 - d. Retighten the bearing or roller cap screws in the stabilizer.
 - e. Remove the string and now the landleveler is ready to use.
6. Operating the machine under adverse conditions, such as extremely rough ground, rocks or stumps, may cause the hitch end bolt to break. If this occurs, do not replace the factory installed bolt with a case hardened bolt. It is intended to be a safety shear pin.
 7. Hydraulic Cylinder option. Adjust cylinder adjusting screw, located on the piston end of the bucket cylinder, so that the pivot point (A) is located 1/8" forward of a direct line between the upper turnbuckle; attach point (B) and the lower attach point (C) on each side of the machine. (See Drawing on the following page)
 8. Adjust the bucket lift turnbuckle to "Level", set blade and working height of the bucket.
 9. Recheck adjustment No. 7 above, to make sure pivot point is within tolerance (0" to 1/8"). If necessary, readjust No. 7 and No. 8 above.

Blank Page

HYDRAULIC BUCKET CYLINDER OPTION

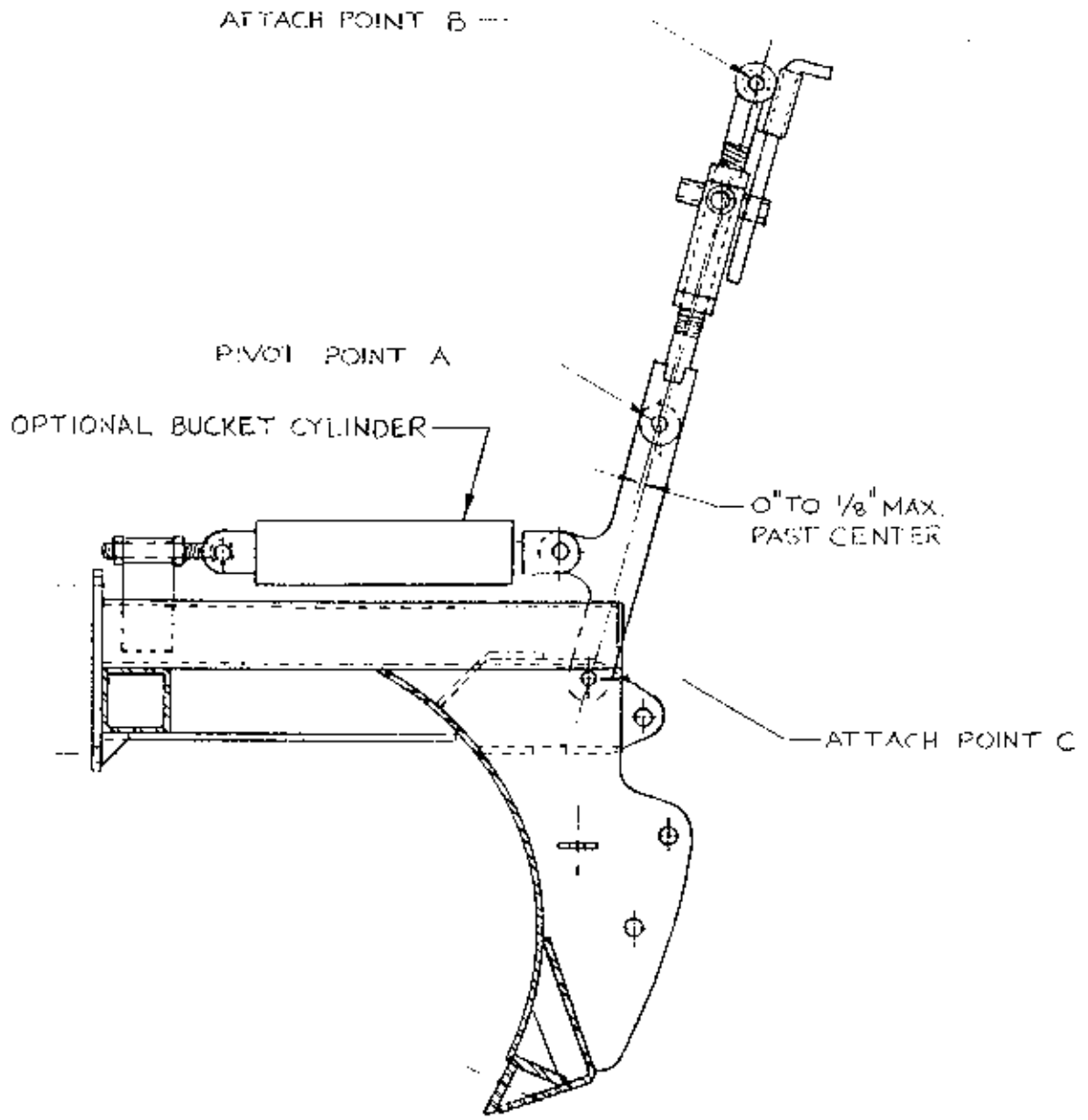
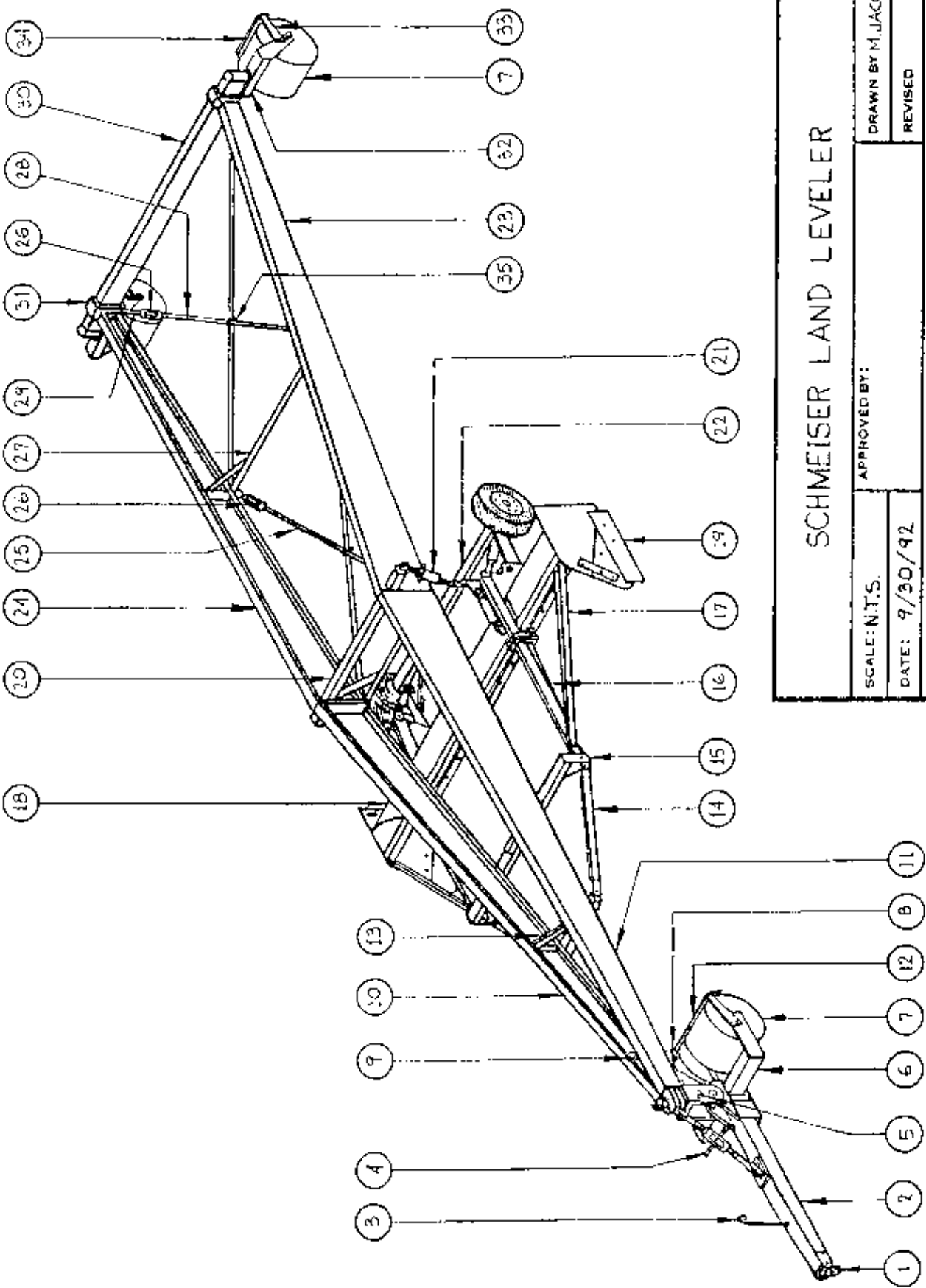

TABLE SLP-1

<u>ITEM#</u>	<u>PART NO.</u>	<u>DESCRIPTION</u>	<u>QUANTITY</u>	<u>NOTES</u>
1.	SLP-Q2	TONGUE HITCH	1	
2.	SLP-Q1	TONGUE	1	
3.	SLP-Q5	HYD. LINE SUPPORT	1	
4.	SLP-Q4	FRONT TURNBUCKLE ASS'Y	1	
5.	SLP-N	MAIN FRAME PIVOT SHAFT	1	
6.	SLP-P1	FRONT STEEL WHEEL FRAME	1	(0) W/QUAD TIRE FRAME
	SLP-P2	QUAD TIRE FRAME (optional)	0	(1)
7.	SLP-D	STEEL WHEELS	4	(2) W/QUAD TIRE FRAME
8.	SLP-A8	PIVOT SHAFT LOCKOUT	1	
9.	SLP-A9	PIVOT SHAFT LOCKOUT PIN	1	
10.	SLP-A1R	TOP FRAME, FRONT - R.H.	1	
11.	SLP-A1L	TOP FRAME, FRONT - L.H.	1	
12.	SLP-P1-9	FRONT SCRAPER BLADE	1	(0) W/QUAD TIRE FRAME
13.	SLP-G	FRONT CROSS FRAME	1	
14.	SLP-J2R	PULL BRACE - R.H.	1	
	SLP-J2L	PULL BRACE - L.H.	1	
15.	SLP-J1	CROSS BRACE - T.F. TO BUCKET	1	
16.	SLP-K	BUCKET PULL ARM	2	
17.	SLP-K-7R	PULL ARM TIE BAR - R.H.	1	SPECIFY BUCKET SIZE
	SLP-K-7L	PULL ARM TIE BAR - L.H.	1	SPECIFY BUCKET SIZE
18.	SLP-14-L1	BUCKET 14'	1	
	SLP-16-L1	BUCKET 16'	1	
	SLP-18-L1	BUCKET 18'	1	
19.	SLP-L2R	BUCKET SIDES - R.H.	1	
	SLP-L2L	BUCKET SIDES - L.H.	1	
20.	SLP-F	CENTER CROSS FRAME	1	
21.	SLP-M	BUCKET LINKAGE	2	
22.	SLP-H	TIRE AXLE	1	
23.	SLP-A2R	TOP FRAME, REAR - R.H.	1	
24.	SLP-A2L	TOP FRAME, REAR - L.H.	1	
25.	SLP-A4	FRONT ROD - 114"	2	
26.	SLP-ABO-1	3/4" X 6" TURNBUCKLE	4	
27.	SLP-E	REAR INSIDE FRAME	1	
28.	SLP-A5	REAR ROD - 126"	2	
29.	SLP-A3	L.H. THRD. STUB END	4	
30.	SLP-14-C1	REAR CROSS FRAME 14'	1	140" LONG
	SLP-16-C1	REAR CROSS FRAME 16' 18'	1	157-1/2" LONG
31.	SLP-C2	REAR FRAME 8" U-BOLT	4	
32.	SLP-B1	REAR STEEL WHEEL FRAME	2	
33.	SLP-B2R	SCRAPER BLADE ARM R.H.	3	}(4) W/QUAD TIRE (2) R.H. (2) L.H.
	SLP-B2L	SCRAPER BLADE ARM L.H.	3	
34.	SLP-B2-3	SCRAPER BLADE - REAR	2	
35.	SLP-ABO-2	1-1/2" U-BOLTS	2	



SCHMEISER LAND LEVELER

SCALE: N.T.S.	APPROVED BY:	DRAWN BY M. JACOBY
DATE: 9/30/92		REVISED
3160 E. CALIFORNIA AVE. FRESNO CA 93714		
COMPLETE ASSEMBLY DRAWING		DRAWING NUMBER SLP-1

NOTE: SEE TABLE SLP-1

TABLE SLP-2

<u>ITEM NO.</u>	<u>PART NO.</u>	<u>DESCRIPTION</u>	<u>QUANTITY</u>
1.	SLP-14-L	BUCKET 14'	1
	SLP-16-L	BUCKET 16'	1
	SLP-18-L	BUCKET 18'	1
2.	SLP-K	BUCKET PULL ARM	2
3.	SLP-K-7R	PULL ARM TIE BAR (R.H.)	1
4.	SLP-K-7L	PULL ARM TIE BAR (L.H.)	1
5.	SLP-J1	CROSS BRACE (Top Frame to Bucket)	1
6.	SLP-L2R	BUCKET SIDE (R.H.)	1
7.	SLP-L2L	BUCKET SIDE (L.H.)	1
8.	SLP-L2-4	BUCKET SIDE ADJ. BLADE	2
9.	SLP-14-L1-23	3/8 X 4 SINGLE BLADE 14'	1
	SLP-16-L1-23	3/8 X 4 SINGLE BLADE 16'	1
	SLP-18-L1-23	3/8 X 4 SINGLE BLADE 18'	1
10.	SLP-14-L1-24	1/2 X 6 DOUBLE BLADE 14'	1
	SLP-16-L1-24	1/2 X 6 DOUBLE BLADE 16'	1
	SLP-18-L1-24	1/2 X 6 DOUBLE BLADE 18'	1

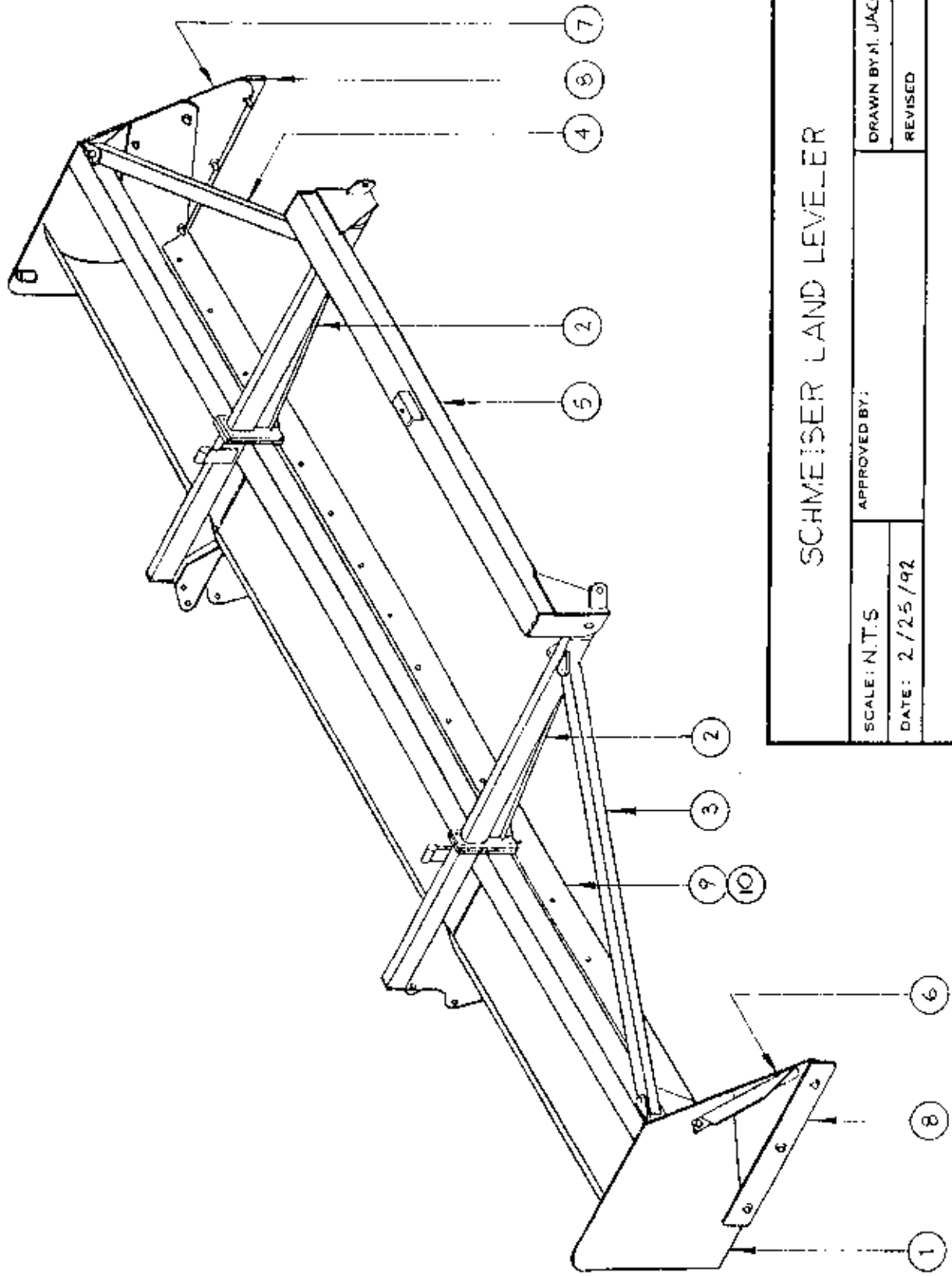

SCHMEISER LAND LEVELER

SCALE: N.T.S.

APPROVED BY:

DRAWN BY: N. JACOBY

DATE: 2/25/92

REVISED

3160 E. CALIFORNIA AVE., FRESNO CA 93714

NOTE: SEE TABLE SLP-2

BUCKET ASSEMBLY DNG.

DRAWING NUMBER
SLP-2

TABLE SLP-3

VARIED QTY'S & LENGTHS

ITEM NO.	PART NO.	DESCRIPTION	QTY'S			MACHINE		
			TYP.	ALL	MACHINES	14"	16"	18"
1.	SLP-14-L1	BUCKET 14'	1			168"		
	SLP-16-L1	BUCKET 16'	1				192"	
	SLP-18-L1	BUCKET 18'	1					216"
2.	SLP-14-L1-23	3/8 x 4 SINGLE BLADE	1					
	SLP-16-L1-23	3/8 x 4 SINGLE BLADE	1				191½"	
	SLP-18-L1-23	3/8 x 4 SINGLE BLADE	1					215½"
	SLP-14-L1-24	1/2 x 6 DOUBLE BLADE	1					
	SLP-16-L1-24	1/2 x 6 DOUBLE BLADE	1				191½"	
	SLP-18-L1-24	1/2 x 6 DOUBLE BLADE	1					215½"
3.	SLP-K-7R	PULL ARM TIE BAR (R.H.)	1					
4.	SLP-K-7L	PULL ARM TIE BAR (L.H.)	1				61-13/16"	72-1/16"
5.	SLP-J2R	PULL BRACE (R.H.)	1				61-13/16"	72-1/16"
6.	SLP-J2L	PULL BRACE (L.H.)	1					
7.	SLP-J1	CROSS BRACE	1					
8.	SLP-K-R	BUCKET PULL ARM (R.H.)	1					
	SLP-K-L	BUCKET PULL ARM (L.H.)	1					
9.	SLP-L2R	BUCKET SIDE (R.H.)	1					
10.	SLP-L2L	BUCKET SIDE (L.H.)	1					
11.	SLP-L2-4	BUCKET SIDE ADJ. BLADE	2					
12.	- - -	5/8" x 1-3/4" FLOW BOLT	-					
13.	- - -	5/8" x 2" Gr.5 z/p BOLTS	16					
14.	- - -	3/4" x 2" Gr.5 z/p BOLTS	12					
15.	- - -	1" x 4-1/2" Gr.5 z/p BOLTS	2					
16.	- - -	5/8" FLAT WASHERS	-					
17.	- - -	5/8" FLAT WASHERS	6					
18.	- - -	5/8" LOCK WASHERS	-					
19.	- - -	5/8" LOCK WASHERS	16					
20.	- - -	3/4" LOCK WASHERS	12					
21.	- - -	5/8" HEX NUTS	-					
22.	- - -	5/8" HEX NUTS	16					
23.	- - -	3/4" HEX NUTS	12					
24.	- - -	1" LOCK NUTS	2					
25.	- - -	1" x 2-1/2" CLEVIS PIN	2					
26.	- - -	1/4" x 1-3/4" LYNCH PIN	2					

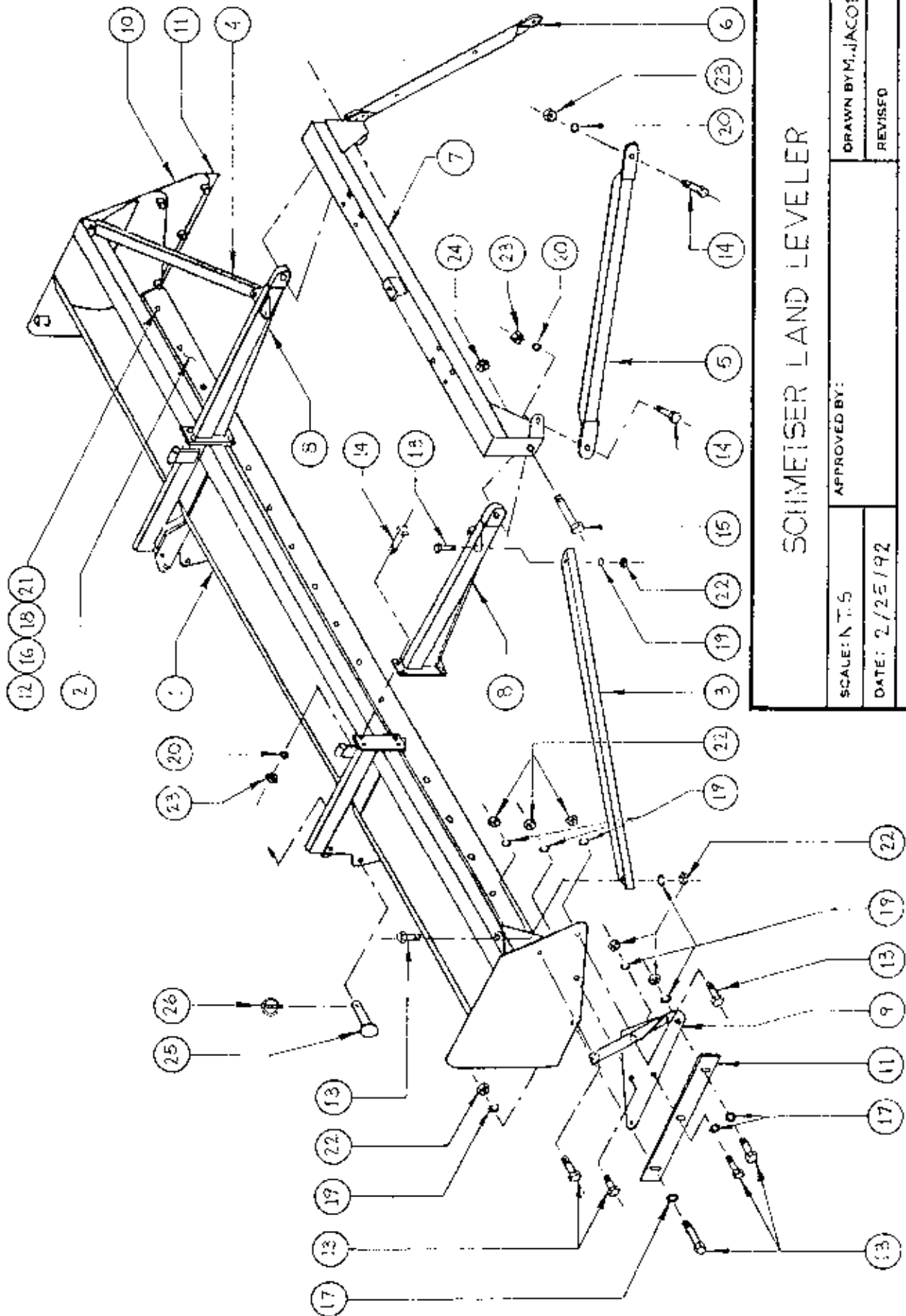

SCHEMEISER LAND LEVELER

SCALE: N.T.S.

APPROVED BY:

DRAWN BY: M. JACOBY

DATE: 2/25/92

REVISED

3160 E. CALIFORNIA AVE., FRESNO CA 93714

BUCKET BOLT-UP ASSEMBLY DWG.

DRAWING NUMBER

SLP-3

NOTE: SEE TABLE SLP-3

TABLE SLP-4

<u>ITEM No.</u>	<u>PART No.</u>	<u>DESCRIPTION</u>	<u>QTY</u>
1	SLP-M4	BUCKET LINKAGE ADJ. ROD	2
2	SLP-M-6	STRAIGHT LINK	2
3	SLP-M-5	T-BAR LINK	2
4	SLP-M2	LOWER TURNBUCKLE STUB	2
5	SLP-M3	TURNBUCKLE CRANK	2
6	SLP-M1	UPPER TURNBUCKLE STUB	2
7	SLP-M1-4	TURNBUCKLE END PLATE	2
8	SLP-M1-5	TURNBUCKLE CRANK ROD	2
9	- - -	1" x 3" Gr. 5 z/p BOLT	4
10	- - -	1" x 6" Gr. 5 z/p BOLT w/ ZERK HOLE	2
11	- - -	1" x 3½" Gr. 5 z/p BOLT w/ ZERK HOLE	2
12	- - -	½" x 1½" Gr. 5 z/p BOLT	2
13	- - -	THREADED GREASE ZERKS	2
14	- - -	PRESSED-IN GREASE ZERKS	6
15	- - -	1" LOCK WASHER	2
16	- - -	½" LOCK WASHER	2
17	- - -	1" z/p HEX NUT	2
18	- - -	1" JAM NUT	4
19	- - -	1" NYLON LOCK NUT	6

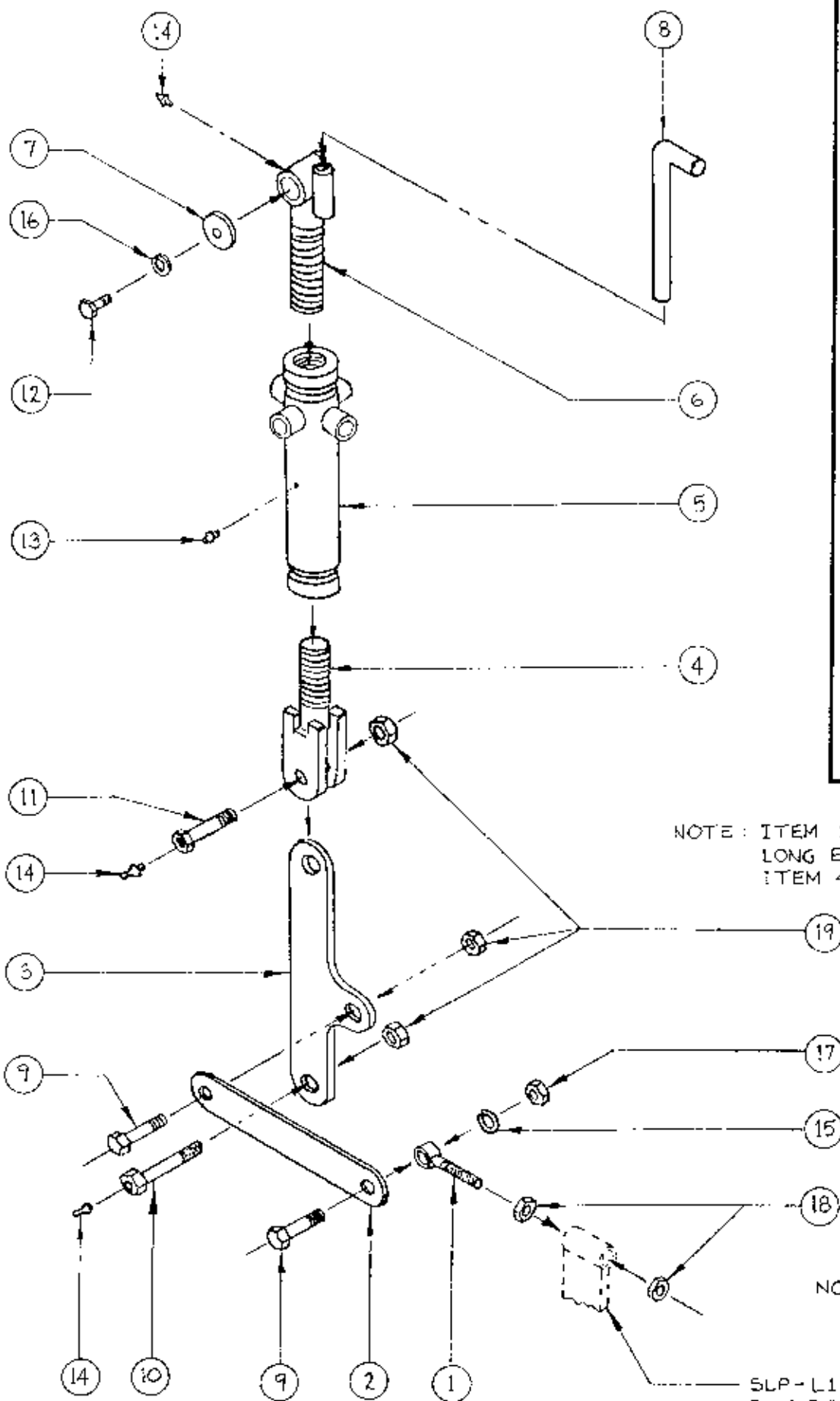

SCHMEISER LAND LEVELER

DRAWN BY M. JACOBY	
REVISED	
APPROVED BY:	
SCALE: N.T.S.	DATE: 2/26/92
3160 E CALIFORNIA AVE., FRESNO CA 93714	
DRAWING NUMBER SLP - 4	
BUCKET LINKAGE ASSEMBLY DWG.	

NOTE: ITEM 3 INSTALLED WITH LONG END ATTACHED TO ITEM 4

NOTE: SEE TABLE SLP-4

SLP-L1 (L1-13, L1-14)
BUCKET REF.

TABLE SLP-5

<u>ITEM NO.</u>	<u>PART NO.</u>	<u>DESCRIPTION</u>	<u>QUANTITY</u>
1	SLP-Q2	TONGUE HITCH	1
2	SLP-Q6	TONGUE HITCH CLEVIS PIN	1
3	SLP-Q5	HYDRAULIC LINE SUPPORT	1
4	SLP-Q1-18	TONGUE LOCKOUT BAR	1
5	SLP-Q1	TONGUE	1
6	SLP-Q7	FRONT WHEEL FRAME BEARING CLAMP	1
7	SLP-P1	FRONT WHEEL FRAME	1
8	- - -	3/4" X 2" GR. 5 Z/P BOLT	6
9	- - -	3/4" FLAT WASHER	1
10	- - -	3/4" LOCK WASHERS	6
11	- - -	3/4" HEX NUT	1
12	- - -	3/4" NYLON LOCK NUT	1
13	- - -	1-1/2" N.F. CASTLE NUT	1
14	- - -	3/4" X 2" CLEVIS PIN	1
15	- - -	1/4" X 1-3/4" LYNCH PINS	2
16	- - -	1/4" X 3" COTTER PIN	1
17	- - -	THREADED GREASE ZERK	1
18	- - -	PRESSED IN GREASE ZERK	1
25	SLP-QBO-J	10", 5000# JACK STAND	1
27	SLP-A6BO-3	THRUST BEARING	1
28	SLP-A6BO-1	OIL SEAL	1
29	SLP-A6BO-4	HOUSING BUSHING	2
30	SLP-P1-14	1/4" SHAFT CAP	1
31	SLP-A6-3	3/8" SHAFT CAP	1
32	SLP-P1-10	BEARING HOUSING	1

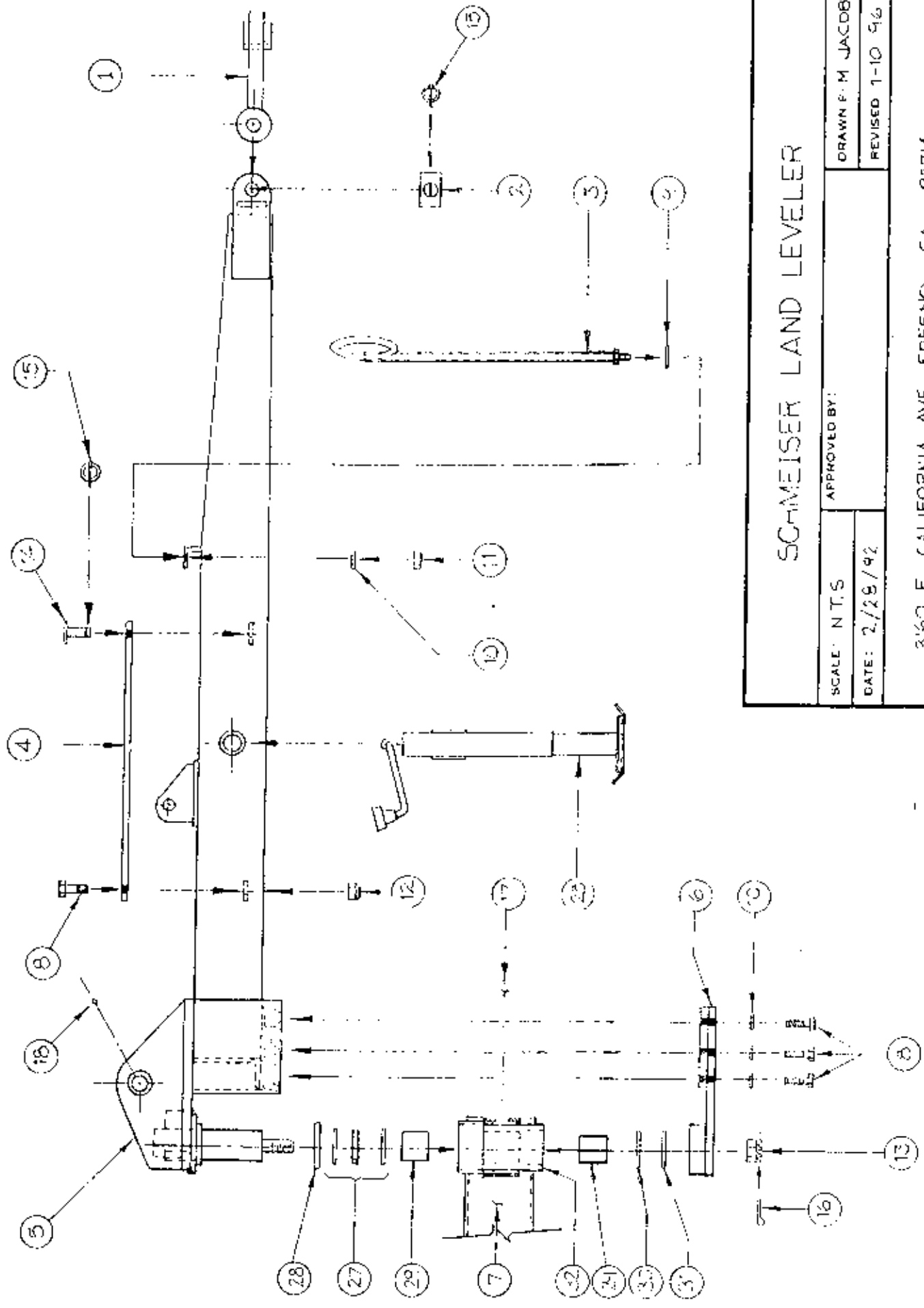

SCHMEISER LAND LEVELER

SCALE: N.T.S. APPROVED BY: DRAWN BY: M. JACOBSON
 DATE: 2/28/92 REVISED: 1-10-92

3160 E CALIFORNIA AVE, FRESNO CA 93714

TONGUE ASSEMBLY DWG

DRAWING NUMBER
 SLP - 5

NOTE: SEE TABLE SUP-5

TABLE SLP-6

<u>ITEM NO.</u>	<u>PART NO.</u>	<u>DESCRIPTION</u>	<u>QTY</u>
1	SLP-N	MAIN FRAME PIVOT SHAFT	1
2	SLP-N-9	FRONT SHAFT CLEVIS PIN	1
3	SLP-A6B0-3	THRUST BEARING	1
4	SLP-A6B0-1	OIL SEAL	1
5	SLP-A6B0-4	HOUSING BUSHING	3
6	SLP-A6F	FRONT BEARING HOUSING	1
7	SLP-A6-3	SHAFT CAP	1
8	SLP-A6B0-5	HOUSING DUST CAP	1
9	- - -	7/8" LOCK NUT	1
10	- - -	THREADED GREASE ZERK	1
11	- - -	1-1/2" N.F. CASTLE NUT	1
12	- - -	1/4" x 3" COTTER PIN	1

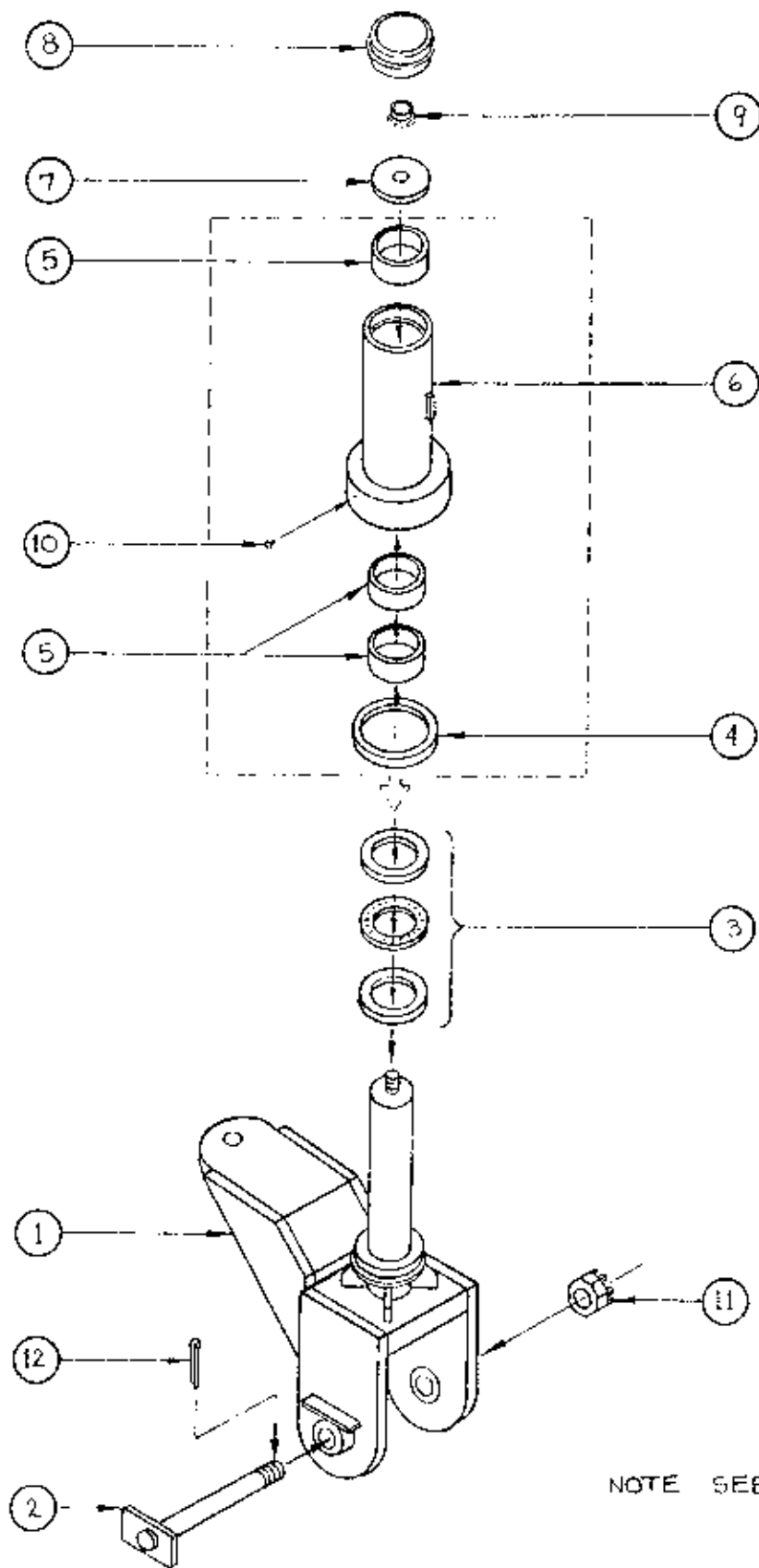

NOTE SEE TABLE SLP-6

SCHMEISER LAND LEVELER

SCALE: N.T.S. APPROVED BY:

DRAWN BY: M. JACOBY

DATE: 11/9/93

REVISED

3160 E. CALIFORNIA AVE. FRESNO, CA 93714

MAIN FRAME PIVOT SHAFT

DRAWING NUMBER
SLP-6

TABLE SLP-7

<u>ITEM No.</u>	<u>PART No.</u>	<u>DESCRIPTION</u>	<u>QTY.</u>
1	SLP-Q4B0-1	TURNBUCKLE BODY	1
2	SLP-Q4-1	R.H. THREADED ROD	1
3	SLP-Q4-2	L.H. THREADED ROD	1
4	- - -	1" x 2-1/2" CLEVIS PIN	2
5	- - -	1/4" x 1-3/4" LYNCH PIN	2

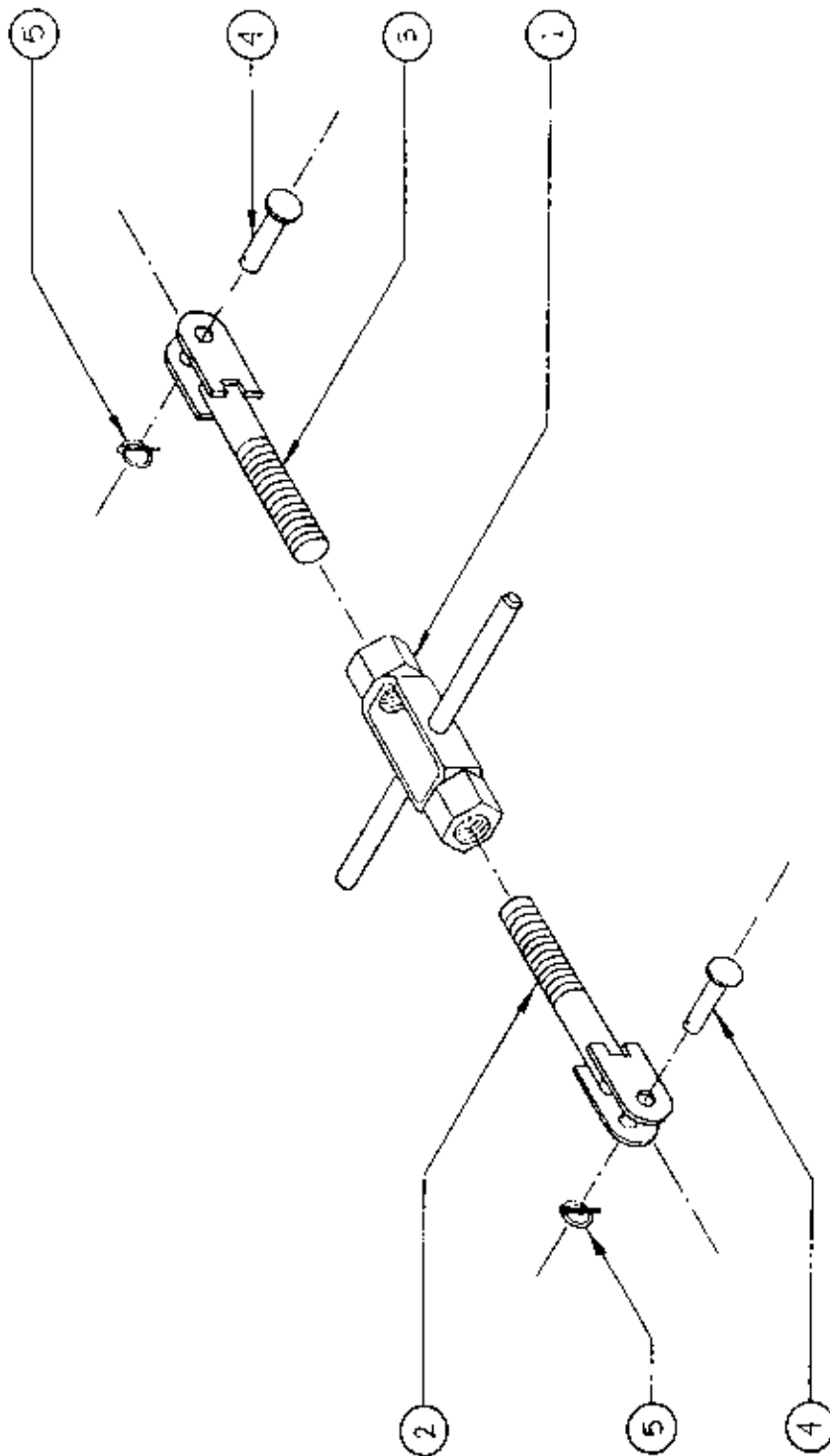

NOTE: SEE TABLE SLP-7

SCHMEISER LAND LEVELER

SCALE: N.T.S.

DATE: 3/25/92

APPROVED BY:

DRAWN BY M. JACOBY

REVISED

3160 E. CALIFORNIA AVE., FRESNO CA 93714

FRONT TURNBUCKLE ASSEMBLY

DRAWING NUMBER
SLP-7

TABLE SLP-8

<u>ITEM No.</u>	<u>PART No.</u>	<u>DESCRIPTION</u>	<u>QTY</u>
1	SLP-F1	FRONT STEEL WHEEL FRAME	1
2	SLP-D	STEEL WHEELS	2
3	SLP-B2	SCRAPER BLADE ARMS 1L.H. 1R.H.	2
4	SLP-F1-9	FRONT WHEEL SCRAPER BLADE	1
5	SLP-DBO-1	1-11/16" FLANGE BEARINGS	4
6	- - -	1/2" x 2-1/4" Gr. 5 z/p BOLTS	16
7	- - -	1/2" x 2" Gr. 5 z/p BOLTS	4
8	- - -	1/2" x 1-1/2" Gr. 5 z/p BOLTS	2
9	- - -	1/2" HEX NUTS	22
10	- - -	1/2" FLAT WASHERS	2
11	- - -	1/2" LOCK WASHERS	22

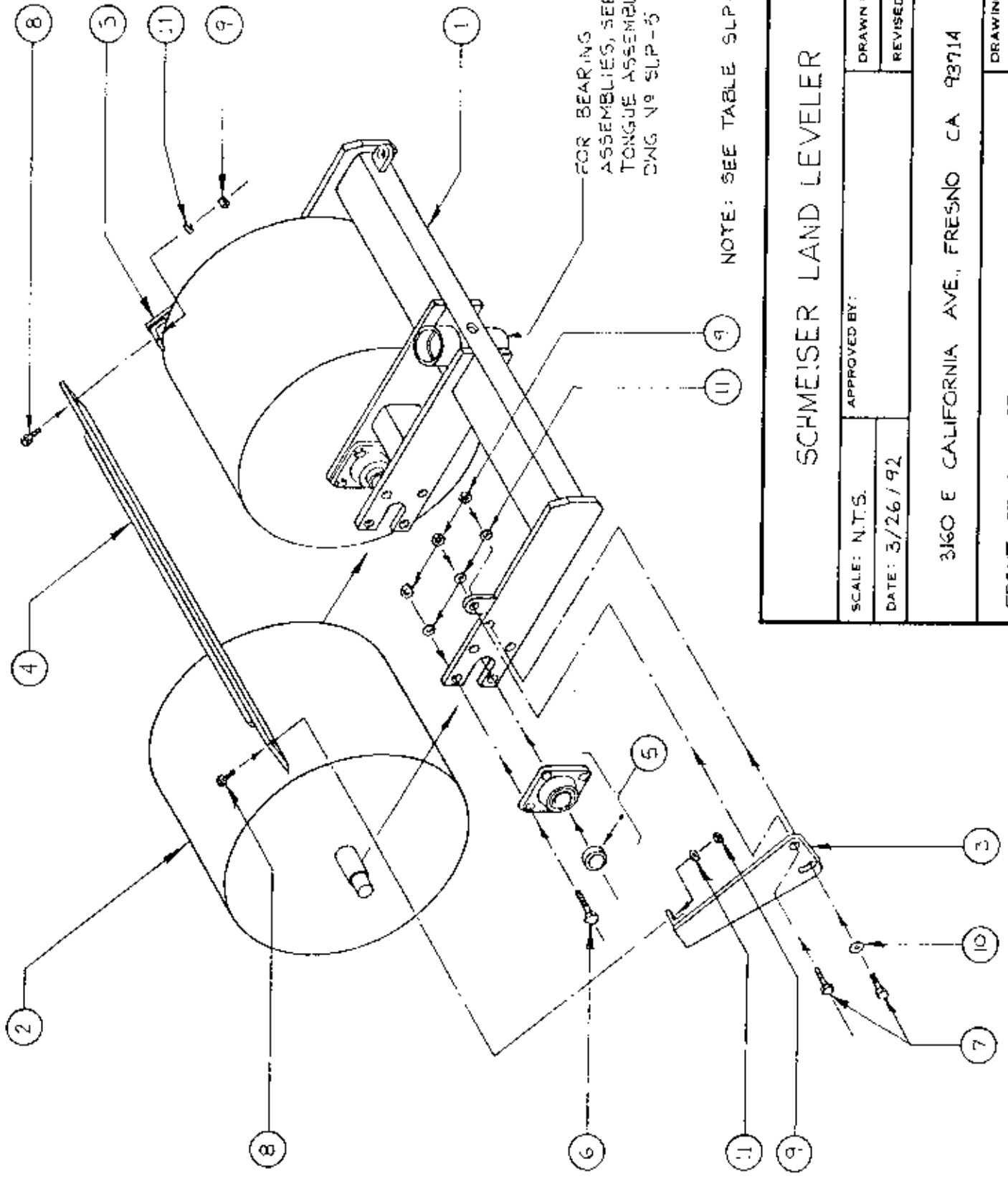

FOR BEARING ASSEMBLIES, SEE TONGUE ASSEMBLY DWG NO SLP-5

NOTE: SEE TABLE SLP-8

SCHMEISER LAND LEVELER

SCALE: N.T.S.	APPROVED BY:	DRAWN BY: M. JACOBY
DATE: 3/26/92		REVISED
3160 E CALIFORNIA AVE., FRESNO CA 93714		
FRONT STEEL WHEEL FRAME ASSEMBLY		DRAWING NUMBER SLP-8

TABLE SLP-9

<u>ITEM NO.</u>	<u>PART NO.</u>	<u>DESCRIPTION</u>	<u>QTY (per machine)</u>
1	SLP-B1	STEEL WHEEL FRAME	2
2	SLP-D	STEEL WHEELS	2
3	SLP-B2	SCRAPER BLADE ARM (2 L.H., 2 R.H.)	4
4	SLP-B2-3	SCRAPER BLADE	2
5	SLP-B3	LOCKING ARM	2
6	SLP-B3-4	LOCKING ARM BEARING BUSHING	2
7	SLP-A6R	REAR FRAME BEARING HOUSING	2
8	SLP-A6-3	SHAFT CAP	2
9	- - -	PUSH-IN GREASE ZERK	2
10	SLP-A6B0-4	HOUSING BUSHING	6
11	SLP-A6B0-3	THRUST BEARING	2
12	SLP-A6B0-1	OIL SEAL	2
13	SLP-B3B0-1	LOCKING ARM BEARING	2
14	SLP-BB0-S	LOCKING ARM SPRING	2
15	SLP-DB0-1	1-11/16" FLANGE BEARINGS	4
16	SLP-A6B0-5	HOUSING DUST CAP	2
17	- - -	1/2" x 1" Gr. 5 z/p BOLTS	2
18	- - -	1/2" x 1-1/2" Gr. 5 z/p BOLTS	4
19	- - -	1/2" x 2" Gr. 5 z/p BOLTS	8
20	- - -	1/2" x 2-1/4" Gr. 5 z/p BOLTS	18
21	- - -	1/2" FLAT WASHERS	10
22	- - -	7/8" LOCKNUT	2
23	- - -	1/2" LOCK WASHERS	30
24	- - -	1/2" HEX NUTS	28
25	- - -	1/2" NYLON LOCK NUT	2
26	- - -	THREADED GREASE ZERKS	2

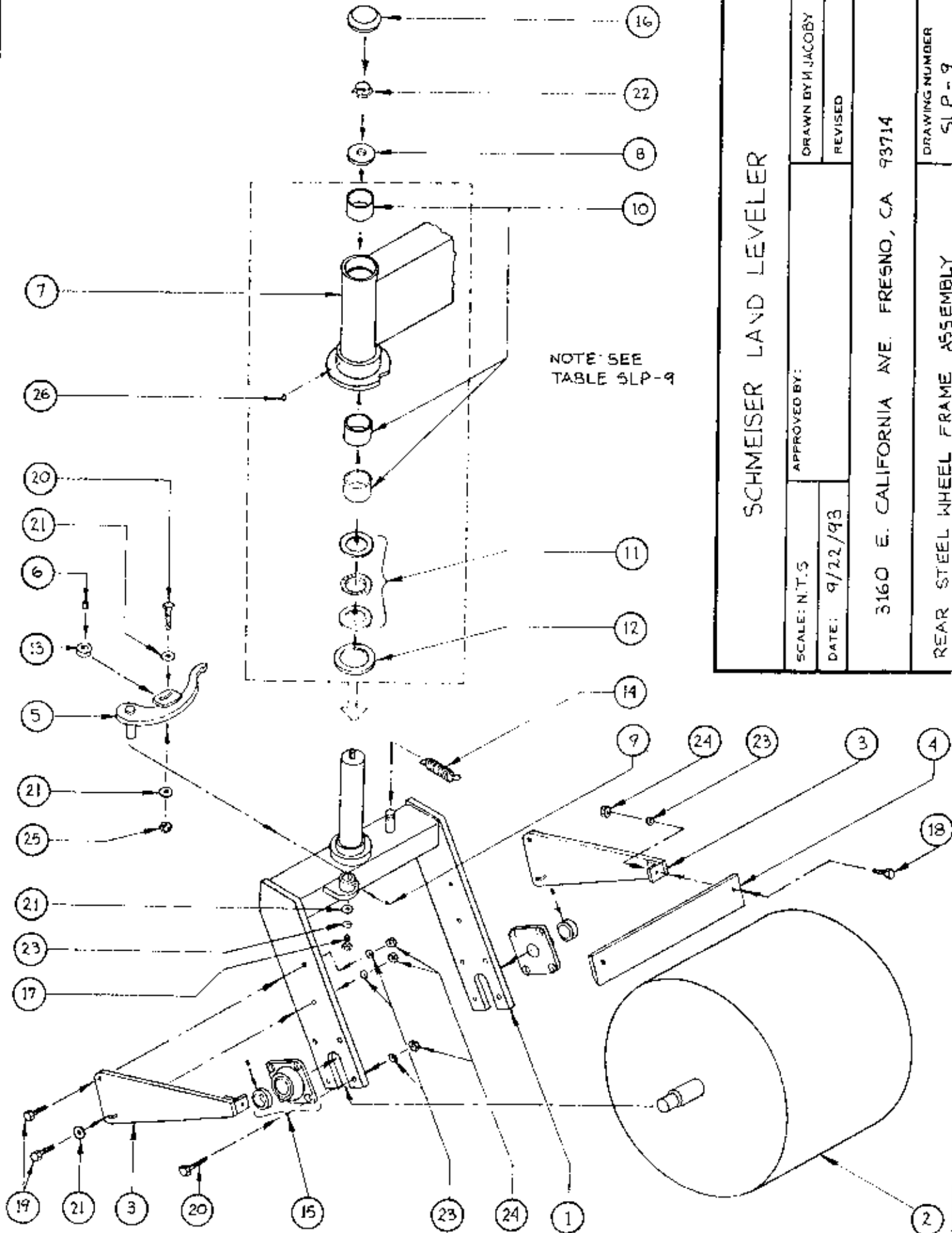

NOTE: SEE TABLE SLP-9

SCHMEISER LAND LEVELER

APPROVED BY:		DRAWN BY: JACOBY	
SCALE: N.T.S.	DATE: 9/22/93	REVISED	
3160 E. CALIFORNIA AVE. FRESNO, CA 93714			
REAR STEEL WHEEL FRAME ASSEMBLY		DRAWING NUMBER SLP-9	

TABLE SLP-10

<u>ITEM No.</u>	<u>PART No.</u>	<u>DESCRIPTION</u>	<u>QTY</u>
1	SLP-HBO-1	OIL SEAL	2
2	SLP-HBO-2	INNER BEARING CONE	2
3	SLP-HBO-3	INNER BEARING CUP	2
4	SLP-HBO-4	HUB, 8-HOLE	2
5	SLP-HBO-5	OUTER BEARING CUP	2
6	SLP-HBO-6	OUTER BEARING CONE	2
7	SLP-HBO-7	DUST CAP	2
8	SLP-HBO-8	10 x 16 WHEEL (8 on 8)	2
9	SLP-HBO-9	12 x 16 TIRE	2
10	SLP-HBO-10	TUBE	2
11	SLP-HBO-11	LUG BOLTS (8 per tire)	16
12	SLP-HBO-12	CASTLE NUT	2
13	SLP-HBO-13	FLAT WASHER	2
14	SLP-H	TIRE AXLE	2
15	- - -	1" x 3-1/2" Gr. 5 z/p BOLTS	2
16	- - -	1" NYLON LOCKNUTS	2
17	- - -	PRESSED-IN GREASE ZERK	2
18	- - -	1/4" x 1-1/2" COTTER PIN	2

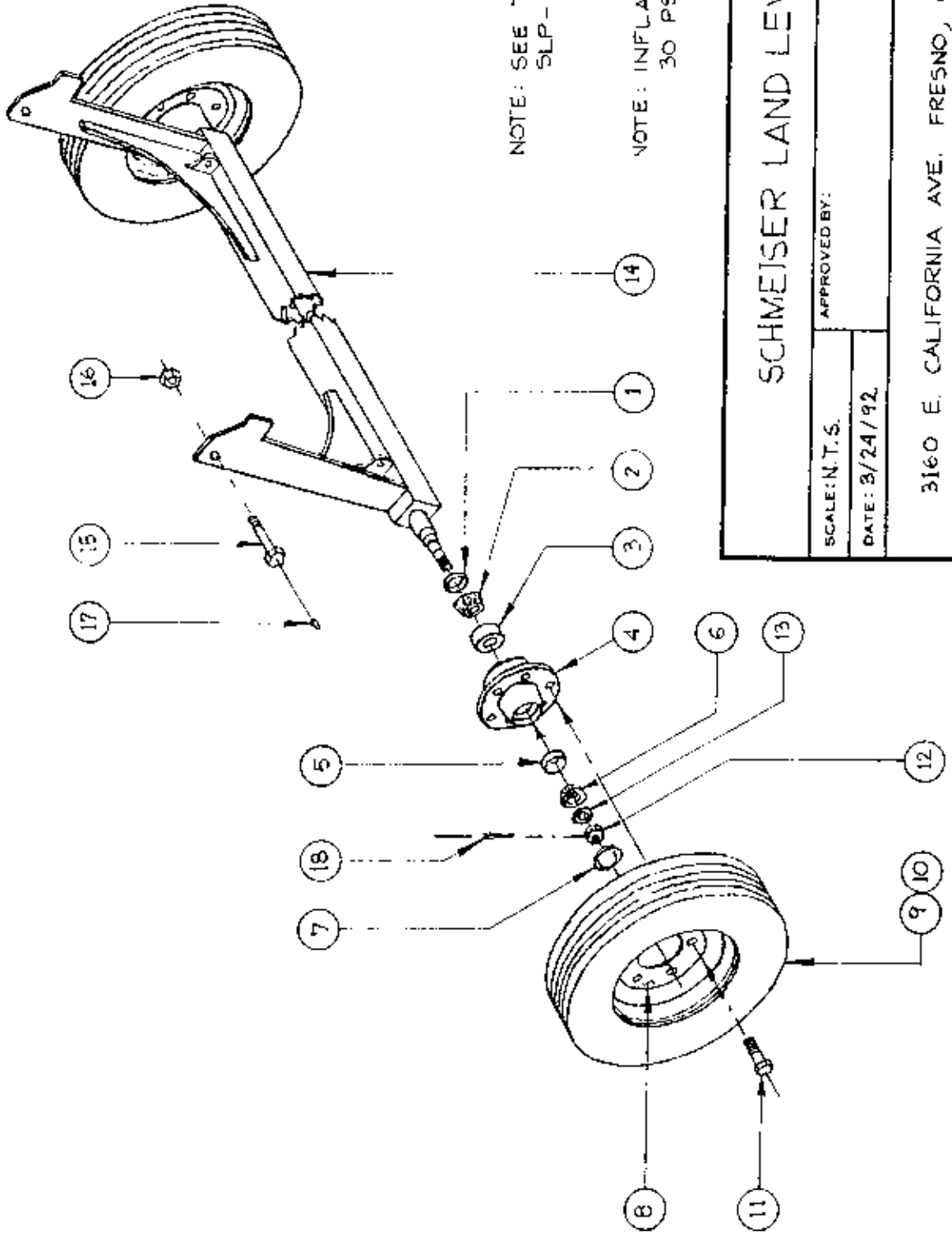

NOTE: SEE TABLE
SLP-10

NOTE: INFLATE TIRES TO
30 PSI

SCHMEISER LAND LEVELER

SCALE: N.T.S.

APPROVED BY:

DRAWN BY R. S. L. JR.

DATE: 3/24/92

REVISED

3160 E. CALIFORNIA AVE. FRESNO, CA 93714

TIRE AXLE ASSEMBLY

DRAWING NUMBER
SLP-10

TABLE SLP-11

<u>ITEM No.</u>	<u>PART No.</u>	<u>DESCRIPTION</u>	<u>QTY</u>
1	SLP-A10B0-1	1/2" PIPE PLUGS	2
2	SLP-A10B0-2	1/2" COUPLINGS	2
3	SLP-A10B0-H.C.	HOSE CLAMPS	5
4	SLP-A10-3	1/2" x 252" PIPE	2
5	SLP-A10B0-3	1/2" HYD. FLOW CONTROL VALVE	1
6	SLP-A10B0-4	1/2" PIPE TEE	1
7	SLP-A10-4	1/2" x 36" PIPE	4
8	SLP-A10B0-5	1/2" x 90 ELBOW	4
9	SLP-A10B0-H.L. 33	HYD. HOSE 1/2" x 33"	2
10	SLP-A10B0-H.L. 41	HYD. HOSE 1/2" x 41"	2
11	SLP-A10B0-H.C. 3 1/2 x 8	HYD. CYLINDER 3 1/2" x 8"	2
12	SLP-A10B0-6	1" HYD. CYL. PINS	4
13	SLP-A10B0-7	HITCH PIN CLIPS	8
14	- - -	5/16" x 2 1/2" Gr. 5 z/p BOLTS	5
15	- - -	5/16" LOCK WASHERS	5
16	- - -	5/16" HEX NUTS	5

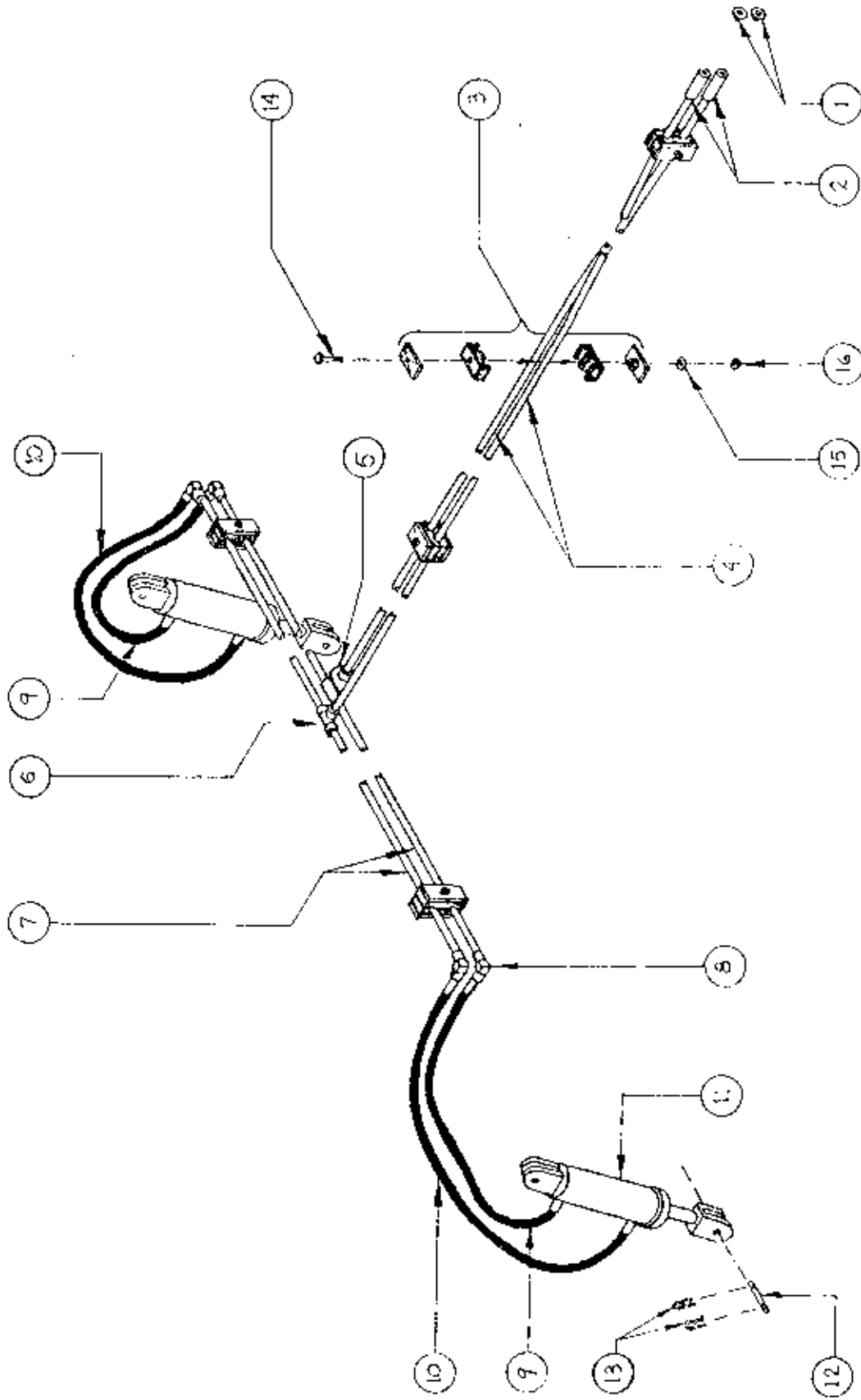

SCHMEISER LAND LEVELER

SCALE: N.T.S.	APPROVED BY:	DRAWN BY: M. JACOBY
DATE: 4/1/92		REVISED
3160 E. CALIFORNIA AVE. FRESNO, CA 93714		
HYDRAULIC SYSTEM ASSEMBLY		DRAWING NUMBER SLP-11

NOTE: SEE TABLE SLP-11

TABLE SLP-12

<u>ITEM NO.</u>	<u>PART NO.</u>	<u>DESCRIPTION</u>	<u>QTY</u>
1.	SLP-A10B0-1	1/2" PIPE PLUGS	2
2.	SLP-A10B0-2	1/2" COUPLINGS	2
3.	SLP-A10B0-H.C.	HOSE CLAMPS	5
4.	SLP-A10-3	1/2" X 252" PIPE	2
5.	SLP-A10B0-3	1/2" HYD. FLOW CONTROL VALVE	1
6.	SLP-A10B0-4	1/2" PIPE TEE	1
7.	SLP-A10-4	1/2" X 36" PIPE	4
8.	SLP-A10B0-5	1/2" X 90 ELBOW	4
9.	SLP-A10B0-H.L.28	HYD. HOSE 1/2" X 28"	2
10.	SLP-A10B0-H.L.36	HYD. HOSE 1/2" X 36"	2
11.	SLP-A10-H.C.3X8	TIE ROD CYLINDER 3" X 8"	2
12.	SLP-M-7	LOCKOUT PINS	4
13.	- - -	1/4" X 3" COTTER PINS	8
14.	- - -	5/16" X 2-1/2" GR.5 Z/P BOLTS	3
15.	- - -	5/16" X 4-1/2" GR.5 Z/P BOLTS	2
16.	- - -	5/16" HEX BOLTS	5
17.	- - -	5/16" LOCKWASHERS	5
18.	- - -	1/4" 1-3/4" LYNCH PINS	4

NOTE: SEE TABLE SLP-12

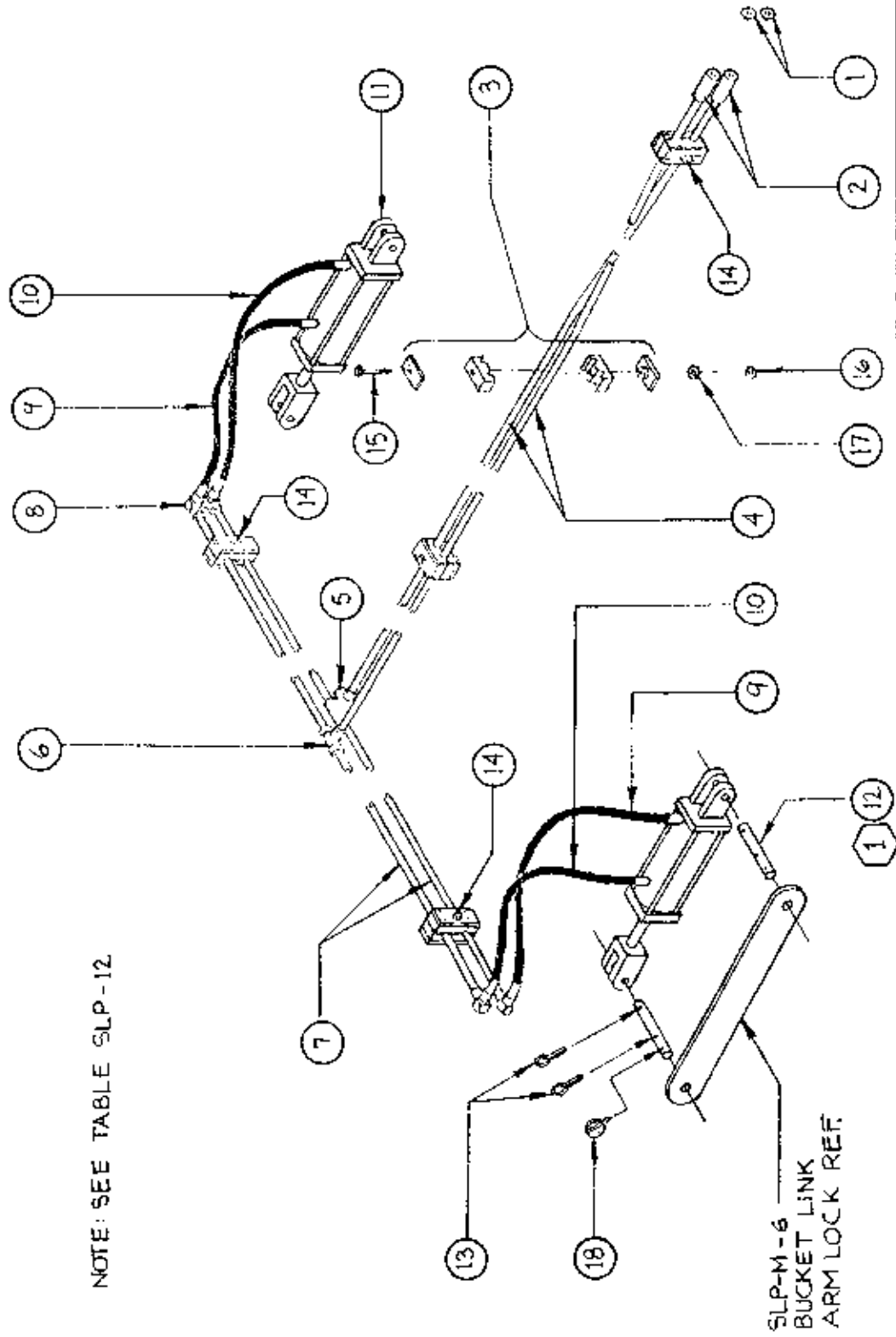

SCHMEISER LAND LEVELER

SCALE: N.T.S.	APPROVED BY:	DRAWN BY M.JACOBY
DATE: 4/3/92		REVISED

3160 E. CALIFORNIA AVE FRESNO, CA 93714

HYDRAULIC BUCKET LIFT SYSTEM ASSEMBLY	DRAWING NUMBER SLP-12
---------------------------------------	--------------------------

1 REPLACES 1" N.C. x 3" BOLT W/
NYLON LOCK NUT

TABLE SLP-13

<u>ITEM No.</u>	<u>PART No.</u>	<u>DESCRIPTION</u>	<u>QTY</u>
1	SLP-P2BO-1	OIL SEAL	4
2	SLP-P2BO-2	INNER BEARING CONE	4
3	SLP-P2BO-3	INNER BEARING CUP	4
4	SLP-P2BO-4	HUB, 6 HOLE	4
5	SLP-P2BO-5	OUTER BEARING CUP	4
6	SLP-P2BO-6	OUTER BEARING CONE	4
7	SLP-P2BO-7	FLAT WASHER	4
8	SLP-P2BO-8	CASTLE NUT	4
9	SLP-P2BO-9	DUST CAP	4
10	SLP-P2BO-10	8 x 15 WHEEL (6 on 6)	4
11	SLP-P2BO-11	9.5 x 15 TIRE	4
12	SLP-P2BO-12	LUG BOLTS (6 per tire)	24
13	SLP-P2	QUAD TIRE FRAME	1
14	- - -	1/4" x 1 1/2" COTTER PIN	4

NOTE: SEE TABLE SLP-13

NOTE: INFLATE TIRES TO 30 PSI

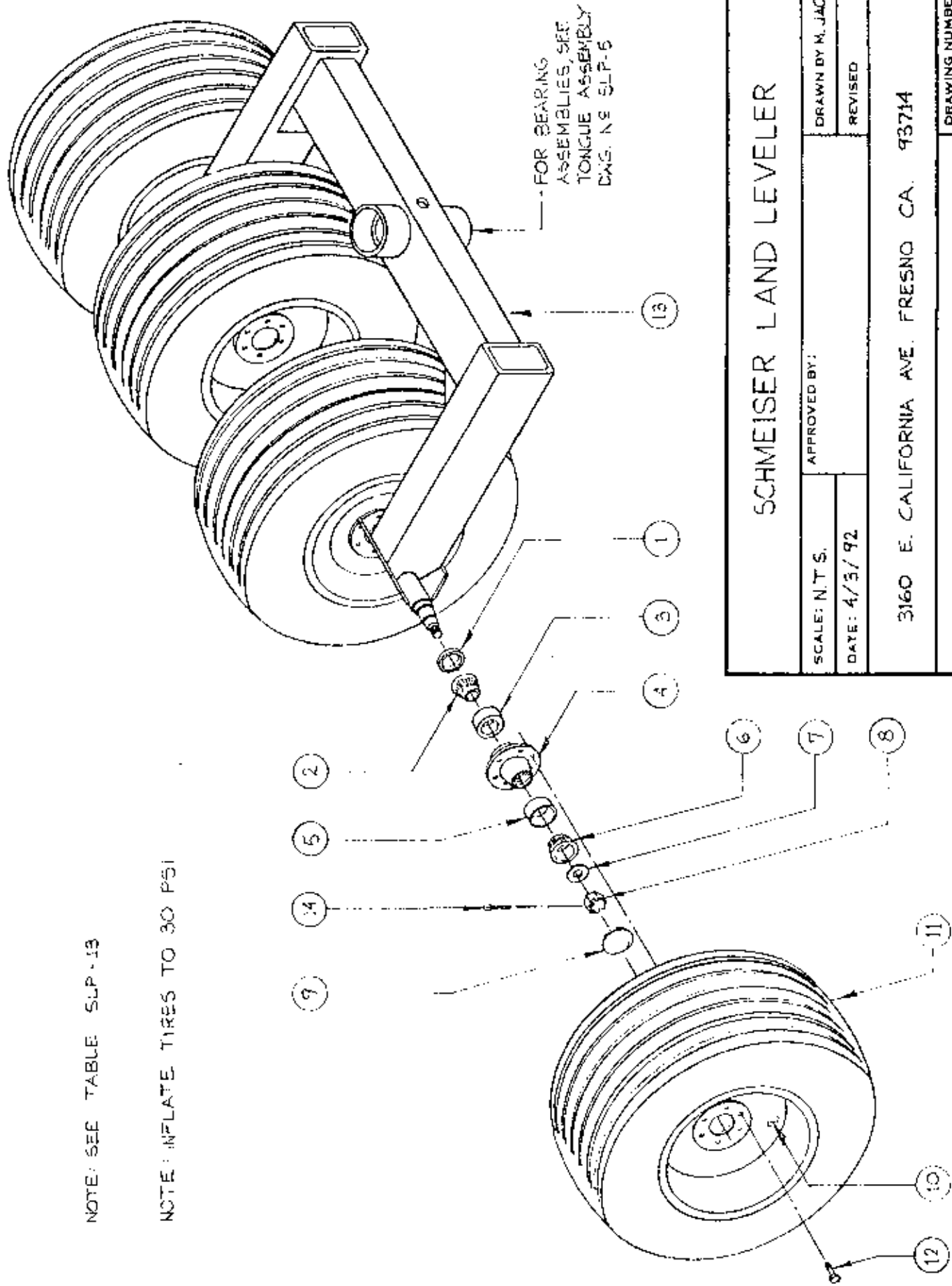

SCHMEISER LAND LEVELER

SCALE: N.T.S.	APPROVED BY:	DRAWN BY M. JACOBY
DATE: 4/3/92		REVISED
3160 E. CALIFORNIA AVE. FRESNO CA. 93714		
QUAD TIRE ASSEMBLY - OPTIONAL -		DRAWING NUMBER SLP-13

LIMITED WARRANTY

T. G. Schmeiser Co. Inc. P.O. Box 1047, Fresno, California 93714, warrants, to the original Retail Customer, the new Schmeiser equipment identified to be free of defects in material and workmanship. Any part of said equipment that, in Schmeiser's judgement, shows evidence of such defects will be repaired without charge, provided that the failure of part(s) shall have occurred within six (6) months from the date of delivery of said equipment to the Retail Customer. Tires, Hoses, Hydraulic components and other trade accessories may be warranted by their respective manufacturers and those warranties, if any, are hereby extended to the Retail Customer. Expendable components such as points, shanks, blades, rings, teeth, and the like are excluded from this warranty.

The Retail Customer must pay the transportation cost to and from the Schmeiser Dealer's service shop for warranty service. Warranty service will be performed by the Schmeiser Dealer from whom the equipment was purchased, in his service shop and during his regularly scheduled days and hours of operation.

All Schmeiser obligations under this warranty shall be terminated if the equipment is modified or altered in ways not approved in writing by Schmeiser, if repair parts other than genuine Schmeiser repair parts have been used, or if the equipment has been subject to misuse, neglect, accident, improper maintenance or improper protection in storage.

Schmeiser reserves the right to make improvements in design or changes in specification at any time without incurring any obligation to owners of equipment previously sold.

No agent or persons has authority to alter, add to or waive the above warranties which agreed to be the only warranties, representation or promises, expressed or implied, as to the quality or performance of the products covered and which do not include any implied warranty of merchantability or fitness. In no event will Schmeiser be liable for incidental or consequential damages or injuries, including, but not limited to, loss of crops, loss of profits, rental of substitute equipment or other commercial loss.